

General Installation Manual

© Jul 2010, Sanyo Electric Co., Ltd. All Rights Reserved. 7/13/10



General Installation Manual for SANYO HIT® Photovoltaic Modules. Please read this manual carefully before installing or using SANYO modules. This manual applies to the following HIT Power products:

- HIT Power 220A (HIT-N220A01)
- HIT Power 215A (HIT-N215A01)
- HIT Power 210A (HIT-N210A01)
- HIT Power 205A (HIT-N205A01)

INTRODUCTION

Thank you for choosing SANYO HIT photovoltaic (PV) modules. With proper operation and maintenance, SANYO HIT PV modules will provide you with clean, renewable solar electricity for many years. This manual contains important installation, maintenance and safety information. The word “module” as used in this manual refers to one or more PV modules. Retain this manual for future reference.

Disclaimer of Liability

SANYO does not assume responsibility and expressly disclaims liability for loss, damage, or expense arising out of, or in any way connected with installation, operation, use, or maintenance by using this manual.

SANYO assumes no responsibility for any infringement of patents or other rights of third parties, which may result from use of modules.

No license is granted by implication or under any patent or patent rights. The information in this manual is believed to be reliable, but does not constitute an expressed and/or implied warranty.

SANYO reserves the right to make changes to the product, specifications, data sheets and this manual without prior notice.

General Information

The installation of solar modules requires a great degree of skill and should only be performed by qualified licensed professionals, including, without limitation, licensed contractors and electricians.

WARNING

- All instructions should be read and understood before attempting to install, wire, operate, and maintain a photovoltaic module. Contact with electrically active parts of the module such as terminals can result in burns, sparks, and lethal shock whether the module is connected or disconnected.
- The installer assumes the risk of all injury that might occur during

installation, including, without limitation, the risk of electric shock.

- PV modules generate DC(direct current) electrical energy when exposed to sunlight or other light sources. Even a single module produces enough voltage and current, to cause shocks and burns if safety precautions are not followed.
- The shock hazard increases as modules are connected in parallel, producing higher current, and as modules are connected in series, producing higher voltages.
- To avoid the hazard of electric sparks, shock, fire, burns, damage and injury:
 - Cover the entire front surface of the PV modules with a dense, opaque material such as a cardboard box, during installation and handling of the modules.
 - Work only in dry conditions, with dry modules and dry tools.
 - Do not stand or step on a modules.
 - Do not puncture, cut, scratch or damage the back sheet of a module. Back sheet damage will void a module's Limited Warranty and may cause fire. *Never use modules with a damaged back sheet.*
 - Do not allow children and unauthorized persons near the installation or storage site of modules.
 - Completely ground all modules.
 - Do not disassemble a module, attempt any repair, open the junction box cover, nor remove any parts installed by Sanyo. There are no user serviceable parts within the module or junction box.
 - Unauthorized persons - except the qualified licensed professional - should not perform any electrical work, including wiring.
 - Wear suitable clothing, guards, eye protection and gloves to prevent you from direct contact with 30 VDC or greater.
 - Wear non-slip gloves and carry modules by the frame using both hands. Do not attempt to carry a module by yourself.
 - Do not carry a module by its wires or junction box.
 - Do not drop anything on the surface of a module.
 - Ensure all system components are compatible, and they do not

subject the module to mechanical or electrical hazards.

- Sparks may occur; do not install modules where flammable gases or vapors are present.
- Never rest or leave a module unsupported or unsecured.
- Do not drop modules.
- Do not use or install broken modules.
- Do not artificially concentrate sunlight on a module.
- Do not touch the junction box terminals.
- Do not change the wiring of bypass diodes.



CAUTIONS

- Use a module for its intended purpose only.
- Do not treat the back sheet, frame, or front surface with paint or adhesives, to avoid reducing its' functionality, damage, and causing inoperable conditions, and other unknown troubles.

GENERAL SAFETY

Follow all permissions, installation and inspection requirements.

- Before installing modules, contact the appropriate authorities having jurisdiction to determine permissions, installation and inspection requirements, which should be followed.
- Electrically ground modules for all systems of any voltage. If not otherwise specified, it is recommended that requirements of the latest National Electrical Code (USA) or Canadian Electric Code (Canada) or other national or international electrical standards be followed. Refer to “Earth Ground Wiring” section for more information.
- Be sure that the building or structure (roof, façade, etc.) where the modules are being installed has enough strength to support the load of the modules.
- For modules mounted on roofs, special structures may be required to help provide proper installation support.
- Both, roof construction and module installation design have an effect on the fire resistance of a building. Improper installation may contribute to fire hazards. Additional devices such as ground fault, fuses, and disconnects may be required.

General Installation Manual

© Jul 2010, Sanyo Electric Co., Ltd. All Rights Reserved. 7/13/10



- Do not use modules of different specifications in the same system.
- Follow all safety precautions of other system components which are used.

UL Listing Information

To satisfy UL requirements, when installing the modules, be sure to:

- 1) Use only stranded or solid copper single-conductor type PV wire or USE-2 cable, 12AWG or larger conductors, rated 600V, 90°C, sunlight resistant, for modules and interconnect wiring that is exposed to weather.
- 2) Observe the requirements described in sections labeled INSTALLATION and SPECIFICATIONS.

INSTALLATION

General

Please read this guide completely before installing or using your Sanyo PV modules. This section contains important electrical and mechanical specifications.

- Modules should be firmly fixed in place in a manner suitable to withstand all expected loads, including wind and snow loads.
- Metals used in locations that are exposed to moisture shall not be employed alone or in combinations that could result in deterioration or corrosion.
- Install modules where they are not shaded by obstacles like buildings and trees. Pay special attention to avoid partially shading the modules by objects during the daytime.
- If needed, contact an Authorized Representative with questions regarding mounting profiles for Sanyo PV modules.

Notes on Installation

- Clearance between the roof surface and module frame is required to allow cooling air to circulate around the back of the module. This also allows any condensation or moisture to dissipate. Install modules so that air can circulate between the roof and the module.
- Leave 1 inch of clearance between the roof and the module frame. If other mounting means are employed this may effect the temperature of the panel.
- SANYO recommends the installation method and mounting profile shown in Figure 1.
- A module should be attached on a mount or support structure rail by metal clamps. The metal clamp must fulfill the following specifications.

Size: not less than 1.5" (38 mm) width

Thickness: not less than 0.12"(3 mm)

Material: aluminum alloy

bolt torque range: 16N.m to 20N.m.

Operating Conditions

SANYO requires that modules be operated within the following Operating Conditions:

- 1) Terrestrial applications only—no outer space or Special Conditions (see below).
- 2) The ambient temperature must be within -20°C (-4°F) to 46°C (115°F). The temperature limits are defined as the Monthly Average High or Low of the installation site.
- 3) The wind pressure load of the installation site should be less than $2,880\text{N/m}^2$ (60PSF).
- 4) Some environmental conditions could apply. Please refer to Sanyo's warranty exclusions.

measured at Standard Test Conditions (STC). STC conditions are; Irradiance of 1000W/m^2 , 25°C cell temperature, and solar spectral irradiance per IEC 60904-3. Note: At the time of shipment, Sanyo guarantees the output level of its modules to be $-0/+10\%$ against Rated Power in SPECIFICATIONS based on Sanyo's factory inspection at STC conditions.

- 2) Under real conditions, a photovoltaic module may experience conditions that produce more current and/or voltage than reported at Standard Test Conditions. Therefore, I_{sc} value of modules should be multiplied by a factor of 1.25 to determine ampacity. An additional factor of 1.25 may be required for sizing conductors, fuses, disconnects, etc. **Please refer to section 690.8 of the National Electrical Code (NEC) for guidelines. The Voc must be factored according to the lowest recorded ambient temperature recorded for the location where the modules will be installed. Please refer to section 690.7 of the NEC for more information regarding voltage**

SPECIFICATIONS

Notes on Specifications

- 1) Rated electrical characteristics are within -5% to $+10\%$ of the values

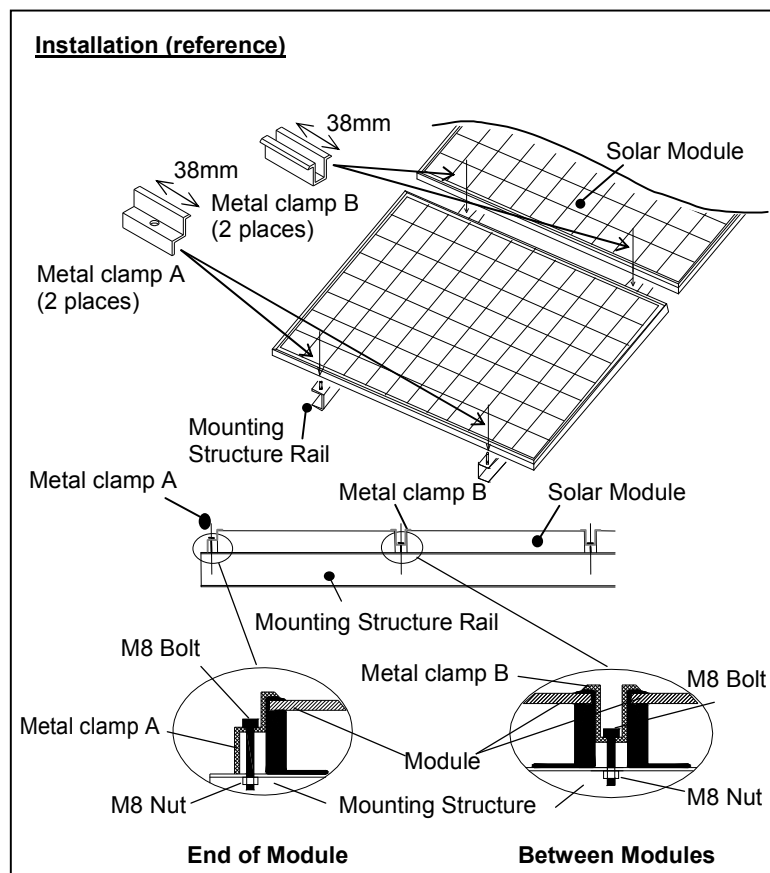

Figure 1. Installation

General Installation Manual

© Jul 2010, Sanyo Electric Co., Ltd. All Rights Reserved. 7/13/10



temperature.

- 3) The current output for the modules shown in the SPECIFICATIONS section is measured at Standard Test Conditions. These conditions may not be frequently observed in actual practice.

Mechanical Loading

- The modules should be mounted at the four (4) quarter points by the means shown in Figure 2.
- This method offers a maximum load of 2,880N/m² (60PSF) in a static state on the module surface.

Note: This mechanical loading value was tested using the following mounting device.

> Provider: UniRac, Inc.

> Part number: SolarMount®

Clamps type: TOP MOUNTING

Clamp size: F size,

Unirac Part No.320029, 320102

WIRING

General

- All wiring should be done in accordance with applicable electrical codes.
- Wiring methods should be in accordance with the NEC in USA or CEC in Canada.
- A qualified, licensed professional should do all wiring.
- Wiring should be protected to help ensure personal safety and to prevent its damage.
- All modules connected in series should be of the same model number and/or type.
- Do not connect modules in parallel without using a connection box.

Module Wiring

- The number of modules that can be wired in series is recommended to be ten (10) or fewer. If connecting eleven (11) modules in series, check local temperature conditions and follow the National Electric Code (690.7) to ensure compliance with maximum voltage limitations.
- When installing a PV array, the system design must be completed with reference to the module electrical specifications for proper selection of inverters, fuses, breakers, charging controllers, batteries and other storage devices.
- These modules contain factory installed bypass diodes. If these modules are incorrectly connected to

each other, the bypass diodes, cable, or junction box may be damaged.

Array Wiring

- The term "array" is used to describe the assembly of several modules on a support structure with associated wiring.
- Use copper wire which insulation is sunlight resistant and can withstand the maximum possible system open circuit voltage.
- Interconnection of modules must be performed in a professional fashion. Wires should be secured and only reasonable slack should be allowed.
- Check local codes for requirements.

Earth Ground Wiring

- All modules should be grounded. All structures or metallic components in direct contact with the modules or electric wires should be properly grounded too. To avoid the hazards of electric shock or fire, modules should be grounded by the frame only the at the locations marked in this manual.
- The array frame shall be grounded in accordance with NEC Article 250 (USA) or CEC in Canada.
- Bonding shall be by a positive means, such as clamping, riveting, bolted or screwed connectors, or welding, soldering or brazing. If the bonding means depends upon screw threads two or more screws or two full threads of a single screw must engage the metal.
- Great care should be exercised to ensure that corrosion caused by the grounding means be avoided. Corrosion can increase the resistance of the grounding connection on the module, or can even cause the grounding connection to fail entirely. Corrosion can be caused by the effects of weather, humidity, dirt and so on. It can also be caused when two dissimilar metals are in contact (galvanic reaction).
 - > Note that the module frame material is aluminum/magnesium alloy.
- All fasteners (nuts, bolts, washers, screws, etc.) must be stainless steel unless otherwise specified. Length of self-tapping screw or bolt should not be more than 0.78"(20 mm) in order to avoid contacting the back-sheet of the module.
- The ground wire must be No.12 AWG (3.5mm²).
- Recommended torque value is 2.3N.m (20in-lb).

- Each ledge on the module frame has two smaller holes for self-tapping screws (0.165" diameter (4.2 mm)) and two larger holes for bolts (0.205" diameter (5.2 mm)). These ground holes are marked with a "G" adjacent to their location on the frame rail (see Figure 3.1). Ground wires must be connected to the module's metal frame at one of these locations.
- There are two methods available to ground modules. Select one method.

>Wire connection using cup washers (see Figures 3.2 and 3.3)

- The use of cup washers is to prevent wire from slipping out from under the screw head (and/or the flat washer).
- Make sure that the cup washer is placed between the wire and the module frame.
- Choose an adequate size for the cup washer and the flat washer so that the wire is fully clamped between them.
- Note: Cup washers are also called as terminal cup washers.
- The cup washers should be stainless steel, or a cup washer made of brass may be used only if a large flat washer made of stainless steel is inserted between the module frame and the cup washer.
- Choose the adequate size for the large flat washer (between the module frame and the cup washer) so that the cup

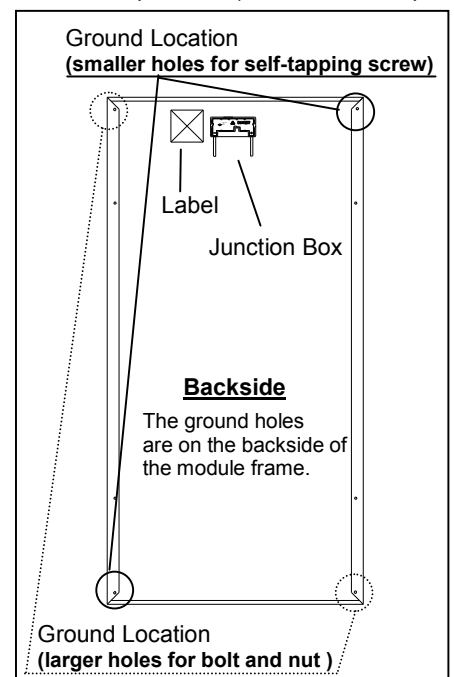

Figure 3.1
Module Ground Position

General Installation Manual

© Jul 2010, Sanyo Electric Co., Ltd. All Rights Reserved. 7/13/10



washer doesn't contact the module frame and is fixed stably to the module frame.

Method 1- Use a self tapping screw (see Figures 3.1 and 3.2)

- If using this method, use one of the smaller holes with diameter of 0.165" (4.2 mm)
- The self-tapping screw size must be No.10 (0.190" diameter (4.83mm)).
- This method requires a minimum number of threads-per-inch to achieve an adequate electrical connection. For a single screw, the thread pitch must be at least 32 threads per inch (TPI). A single screw less than 32 TPI does not provide sufficient thread contact. Note: Self-tapping screws are also called as thread cutting screws.

Method 2- Use a bolt and nut (see Figures 3.1 and 3.3)

- If using this method, use one of the larger holes with diameter of 0.205" (5.2 mm)
The bolt and nut size should be No.8 (0.164" diameter (4.16 mm)), or No.10 (0.190" diameter (4.83 mm)) or M5 (0.197" diameter (5.0 mm)).
- Star washers must be used to make contact through the anodization of the module for this method.
- In this case, the screw threads are not providing the electrical ground contact.

Module Terminations

- A junction box as a terminal enclosure is equipped for electrical connections.
- Modules are equipped with MC™ plugs as a terminal enclosure. Use these MC™ plugs for electrical connections.

Junction Box and Terminals

- Modules are equipped with one junction box containing terminals for both, positive and negative polarity, and bypass diodes.
- Each terminal is provided with factory installed lead cables and latching connector for series and string connections. Always use these connectors and do not detach them from cables.
- Latching connectors and type IV and made by Multi-Contact. Supplied connectors are listed by UL.
- In order to comply with NEC 2008, a locking sleeve needs to be used with all connectors that are exposed.
- The locking sleeve (PV-SSH4) is made by Multi-Contact and can only be released with a special tool also made by Multi-Contact (PV-MS). Locking

sleeves are not supplied with modules and must be purchased separately.

Conduit

- In applications where wire raceways or conduit are used, follow the applicable codes for outdoor installations.
- Verify that all fittings are properly installed to protect wires against damage and prevent moisture intrusion.

DIODES

Bypass Diodes

- When modules in series strings are partially shaded, it may cause reverse voltage across cells or modules, because the current from other cells in the same series is forced to flow through the shaded area. This may cause undesirable heating to occur.
- The use of a diode to bypass the shaded area can minimize both heating and array current reduction.
- Modules are equipped with factory installed bypass diodes. The factory-installed diodes provide proper circuit protection for the systems within the specified system voltage, so that you do not need any other additional bypass diodes.
- Contact your SANYO Authorized Representative for proper diode type, if it is necessary to add or change diodes due to system specifications.

MAINTENANCE

- Some maintenance is recommended to maintain optimal output performance of the solar modules.
- If the module surface becomes dirty, it may reduce output power.
- It is recommended to clean the surface of the module with water and a soft cloth or sponge, twice or more per year.
- A mild non-abrasive detergent may be applied for persistent dirt.
- It is also recommended to inspect the electrical and mechanical connections annually.
- If you need electrical or mechanical inspection or maintenance, it is recommended to have a licensed authorized professional carry out the inspection or maintenance to avoid the hazards of electric shock or injury.

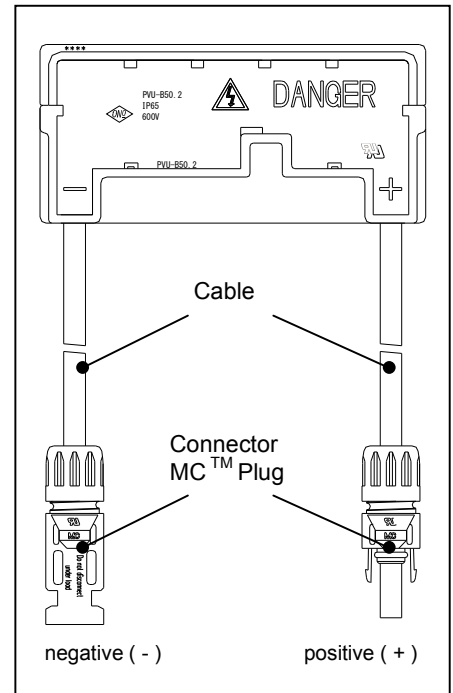

Figure 4 Configuration of Junction Box

The return of any modules will not be accepted by SANYO unless prior written authorization has been given by SANYO.

As part of SANYO's policy of continuous improvement, SANYO reserves the right to change product specifications at any time without prior notice.

For further information, please visit sanyo.com/solar or contact your SANYO Authorized Representative.

General Installation Manual

© Jul 2010, Sanyo Electric Co., Ltd. All Rights Reserved. 7/13/10

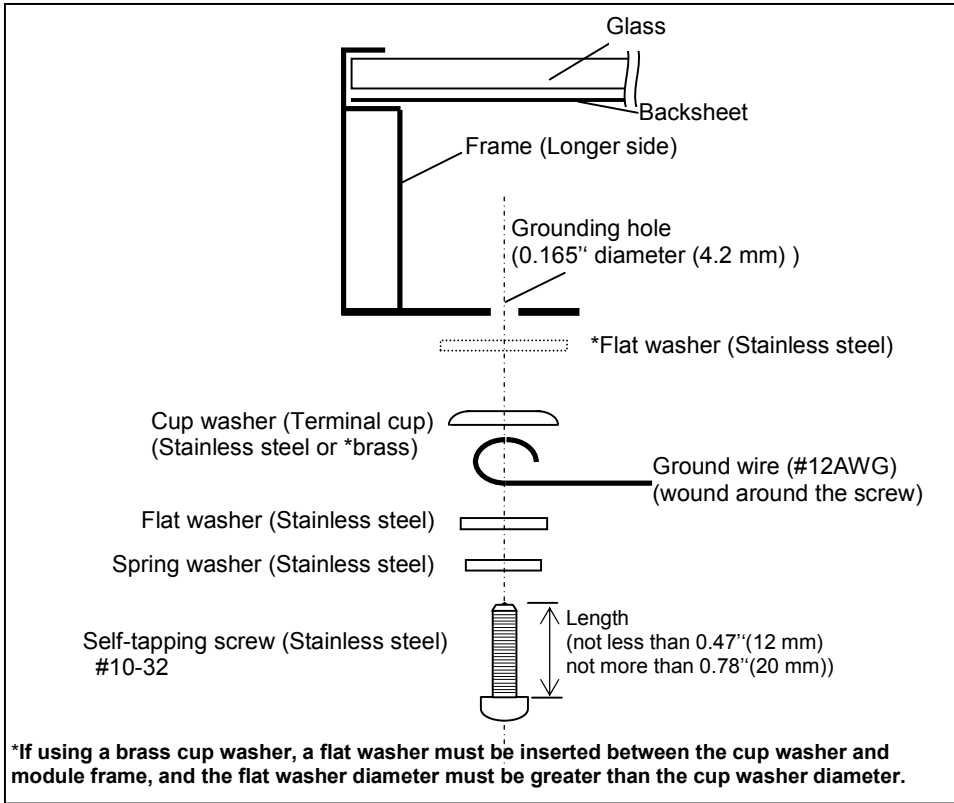

Figure 3.2 (Method 1)
Grounding method
using self-tapping screw

Note: Use the smaller ground holes illustrated in Figure 3.1.

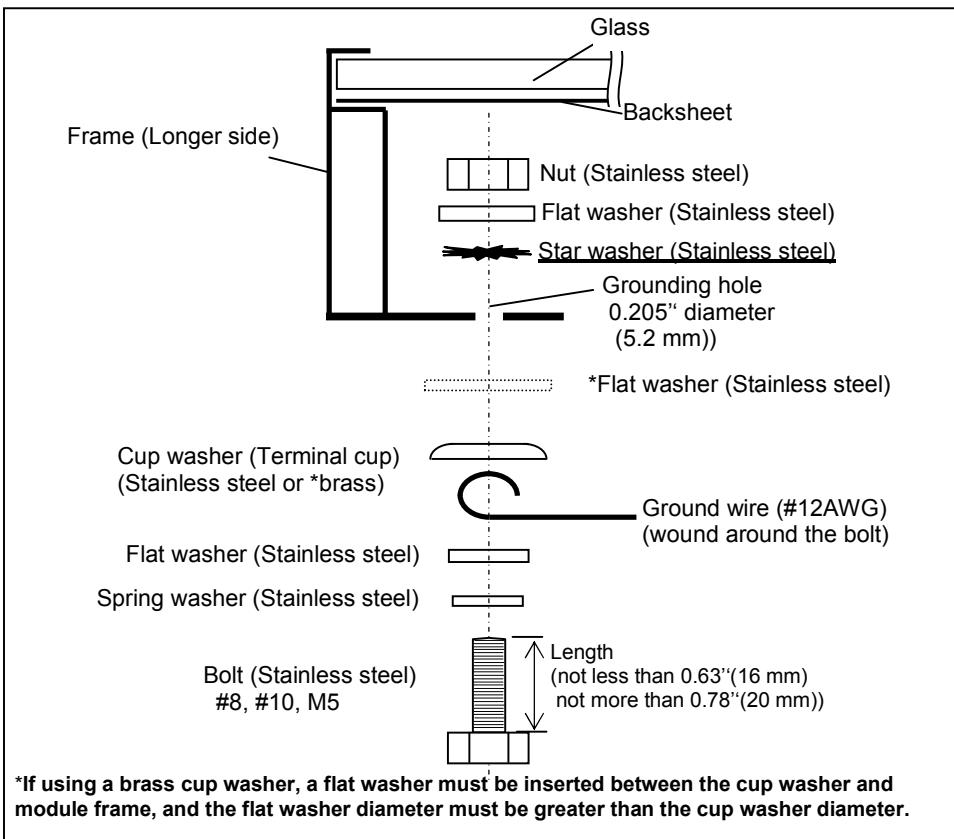

Figure 3.3 (Method 2)
Grounding method
using bolt and nut

Note: Use the larger ground holes illustrated in Figure 3.1.

General Installation Manual

© Jul 2010, Sanyo Electric Co., Ltd. All Rights Reserved. 7/13/10



SPECIFICATIONS

Electrical Specifications

Model	HIT Power 220A (HIT-N220A01)	HIT Power 215A (HIT-N215A01)	HIT Power 210A (HIT-N210A01)	HIT Power 205A (HIT-N205A01)
Cell Number in Series	72	72	72	72
Rated Power, Watts (Pmax)	220	215	210	205
Maximum Power Voltage (Vpm)	42.7	42.0	41.3	40.7
Maximum Power Current (Ipm)	5.17	5.13	5.09	5.05
Open Circuit Voltage (Voc)	52.3	51.6	50.9	50.3
Short Circuit Current (Isc)	5.65	5.61	5.57	5.54
Cell Type	HIT	HIT	HIT	HIT
Maximum System Voltage (Voc)	600	600	600	600
Factory Installed Bypass Diodes	3	3	3	3
Maximum series fuse (A)	15	15	15	15

Mechanical Specifications

Length, mm (inches)	1580 (62.2)
Width, mm (inches)	798 (31.4)
Frame Depth, mm (inches)	46 (1.8)
Weight, kg (pounds)	16 (35.3)

Dimensions

All HIT Power A Models (HIT-NxxxA01)

Dimensions in mm

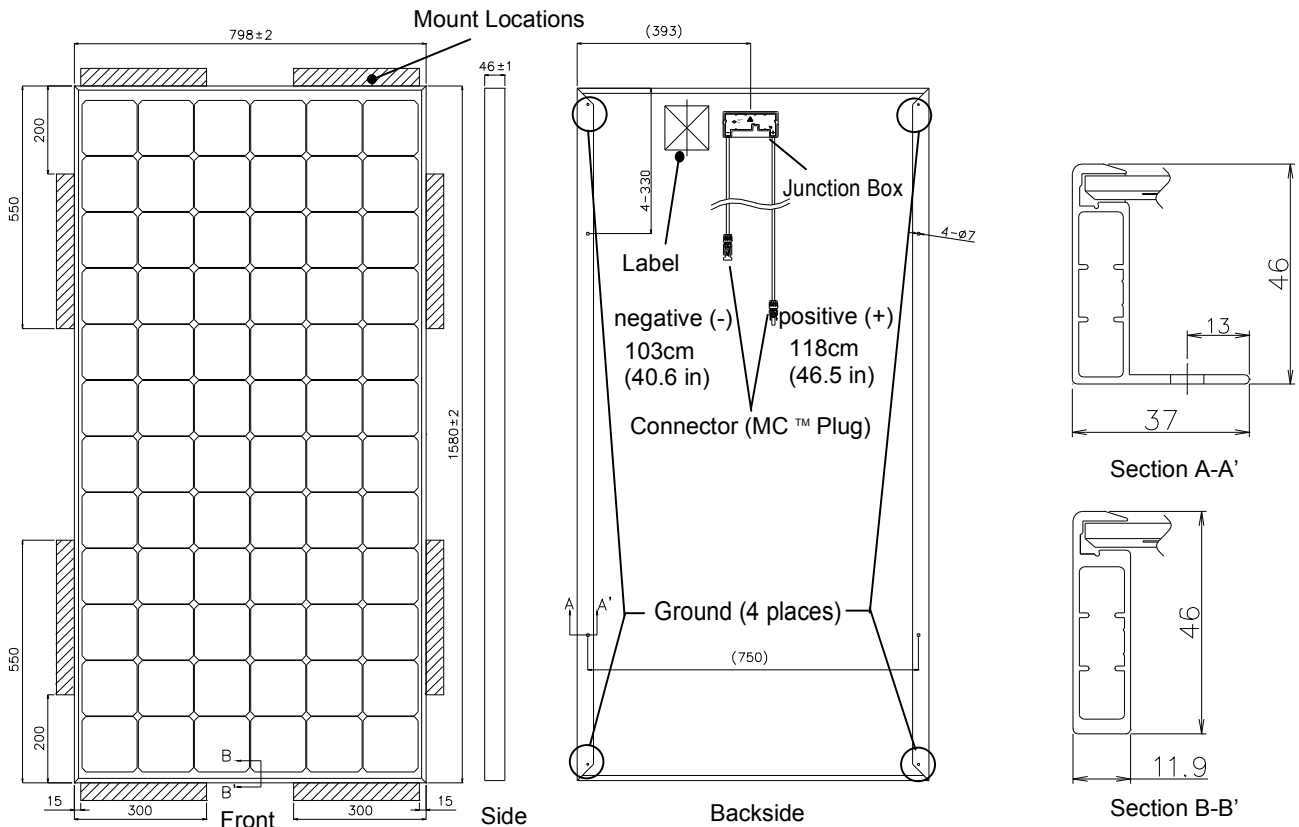

Note : A module should be installed on a mounting structure rail in accordance with the following
 > Use four (4) symmetrical mounting within setting range A.

 : range A

Figure 2 Dimensions